

# The BENJAMIN ArcLight Track Light Limiter Panel™

## Specifications

<b>Voltage Ratings:</b>	120V 1Ø 2W	277V 1Ø 2W						
<b>AIC Ratings:</b>	10kAIC @ 120V Fully Rated	6kAIC @ 277V Fully Rated						
<b>Circuit Breaker Current Ratings (single pole):</b>	0.5 Amp	1 Amp	2 Amp	3 Amp	4 Amp	5 Amp	6 Amp	7 Amp
	8 Amp	10 Amp	13 Amp	15 Amp	16 Amp	20 Amp	25 Amp	30 Amp
	32 Amp	40 Amp	50 Amp	60 Amp				
<b>Certification:</b>	Underwriters Laboratories Listed, UL508A							

## Panel Dimensions

Surface Mount Panel - up to 16 Circuits

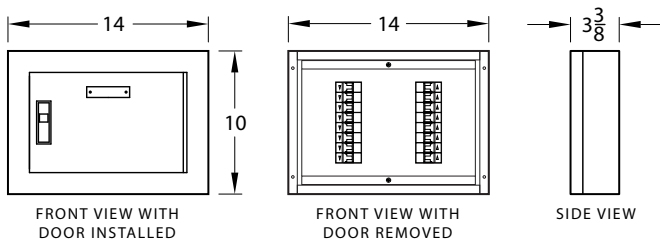

Flush Mount Panel - up to 16 Circuits

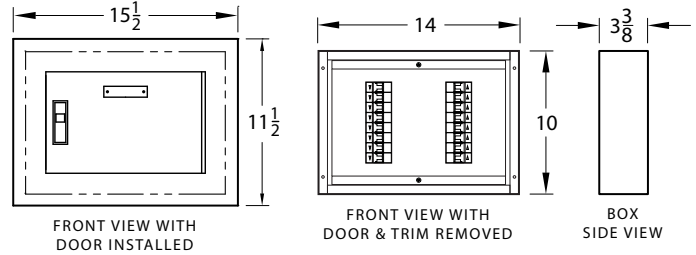

Surface Mount Panel - up to 32 Circuits

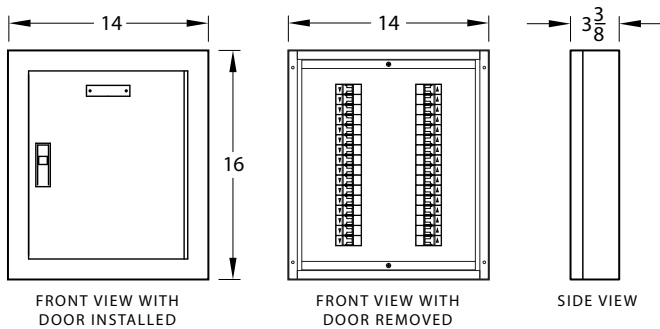

Flush Mount Panel - up to 32 Circuits

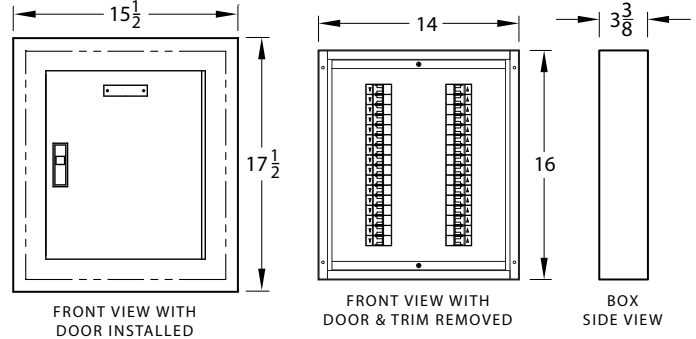

## Typical Wiring Diagram

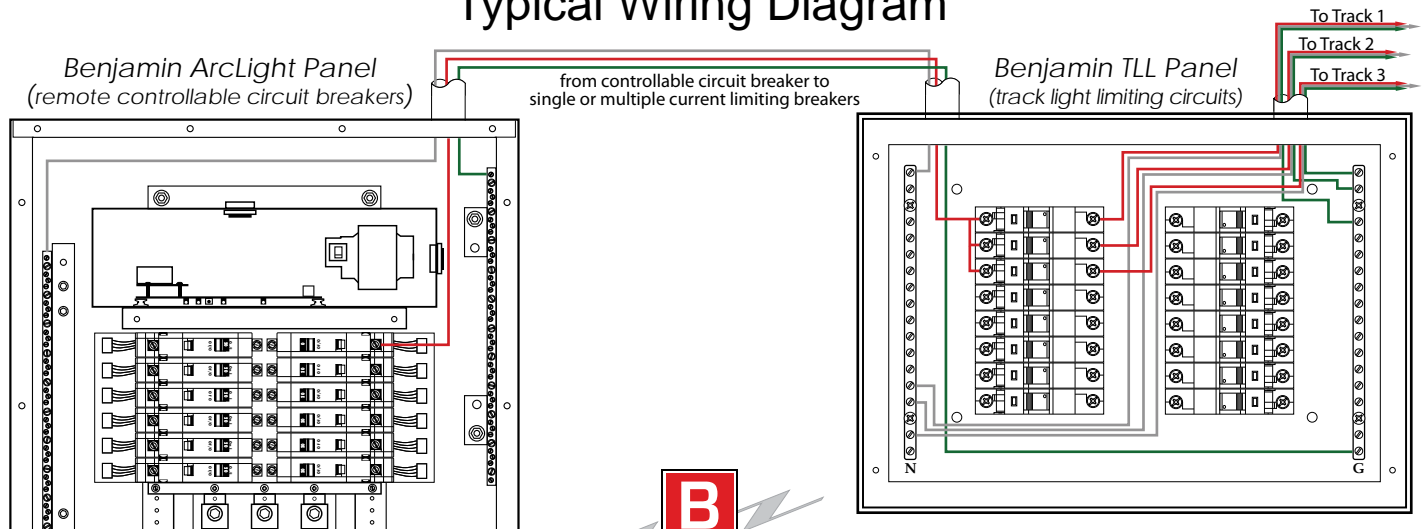

Manufacturers of Quality Electrical Power Distribution Equipment