

The BENJAMIN Track Light Limiter Panel

Specifications

Voltage Ratings:	120V 1Ø 2W	277V 1Ø 2W						
AIC Ratings:	10kAIC @ 120V Fully Rated	6kAIC @ 277V Fully Rated						
Circuit Breaker Current Ratings (single pole):	0.5 Amp	1 Amp	2 Amp	3 Amp	4 Amp	5 Amp	6 Amp	7 Amp
	8 Amp	10 Amp	13 Amp	15 Amp	16 Amp	20 Amp	25 Amp	30 Amp
	32 Amp	40 Amp	50 Amp	60 Amp				
Certification:	Underwriters Laboratories Listed, UL508A							

Panel Dimensions

Flanged Trim Panel - up to 16 Circuits

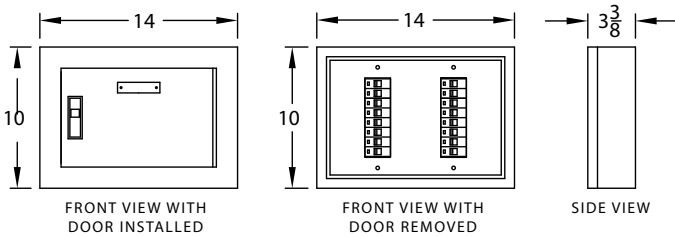

Flush Trim Panel - up to 16 Circuits

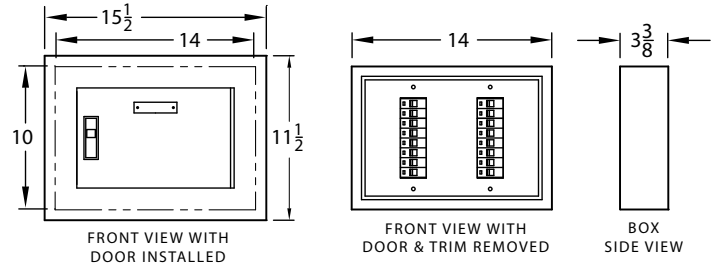

Flanged Trim Panel - up to 32 Circuits

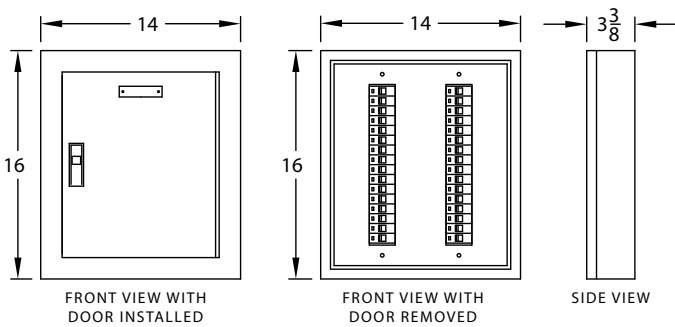

Flush Trim Panel - up to 32 Circuits

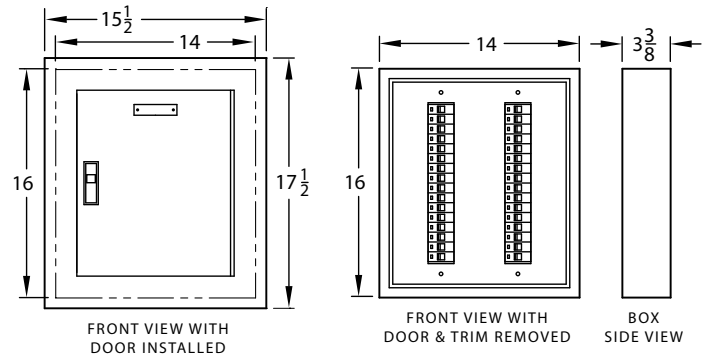

Typical Wiring Diagram

Benjamin ArLight Panel
(remote controllable circuit breakers)

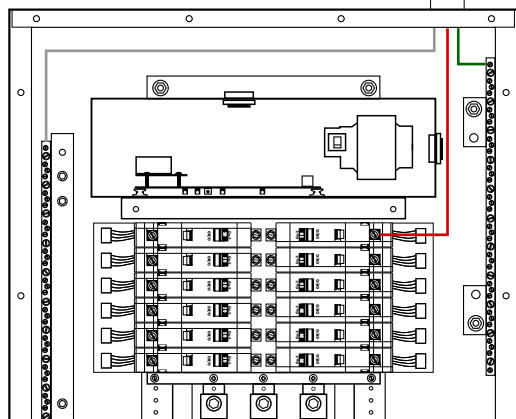

from controllable circuit breaker to single or multiple current limiting breakers

Benjamin TLL Panel
(track light limiting circuits)

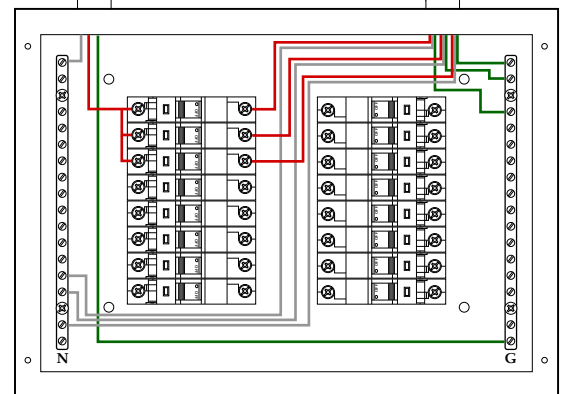

Manufacturers of Quality Electrical Power Distribution Equipment